

# Assembly Instructions

## What's Included



Piano Body Bolts (A) x 2



Back Panel Bolts (B) x 2

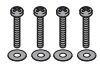

Back Panel Bolts (C) x 4

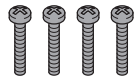

Pedal Board Bolts (D) x 4



Headphone Bolts (E) x 4



Cable Clips (F) x 4



Headphones holder

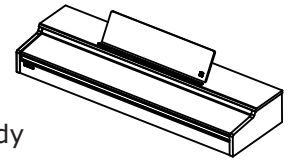

Piano Body

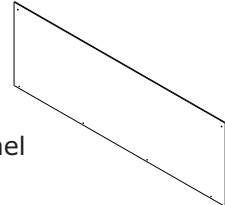

Back Panel

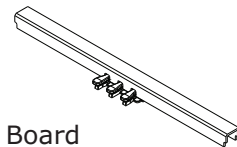

Pedal Board

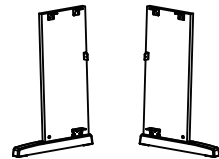

Legs (2)

## 1. Attaching the Pedal Board

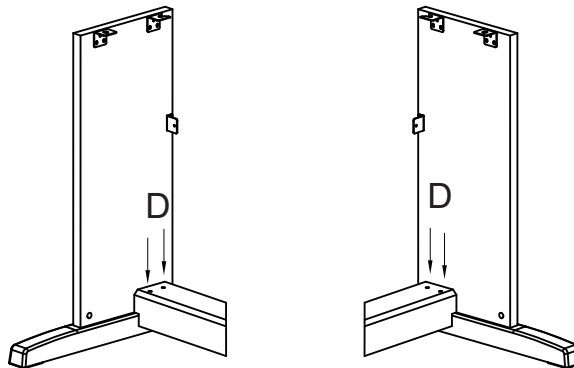

Starting with the right Stand Leg, align the holes in the Pedal Board with the holes in the Pedal Board Bracket as shown. Make sure that the pedals are facing towards the front of the Stand Legs.

Thread two Pedal Board Bolts (D) through the Pedal Board and into the bracket. Repeat with the left Stand Leg and tighten all bolts fully.

## 2. Attaching the Back Panel and Piano Body

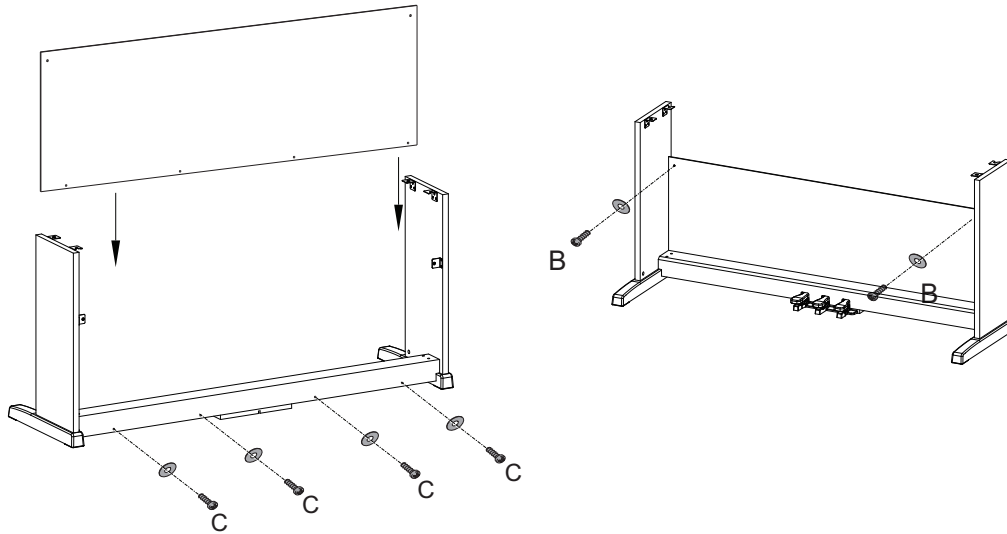

Using four Back Panel Bolts (C) with washers, and two Back Panel Bolts (B) with washers, attach the Back Panel to the stand.

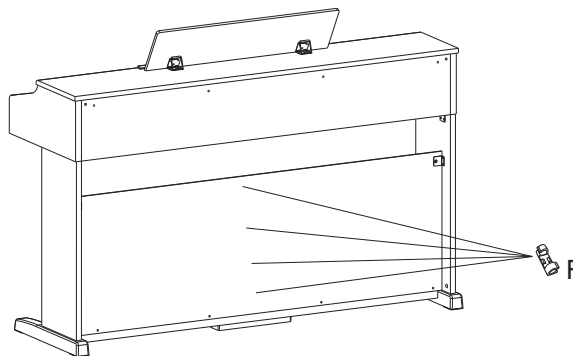

Attach four cable clips(F) to secure the cable.

Lift onto stand slide forward,

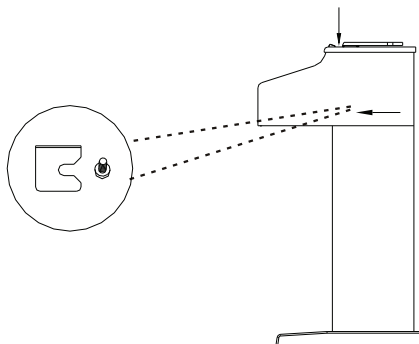

With help from another person, lift the piano onto the stand and slide forwards, pushing the guide rods on the bottom of the piano into the slots on the Stand Legs, as shown below.

When lifting the piano onto its stand, be careful not to catch/trap hands or fingers.

### **3. Securing the Piano Body**

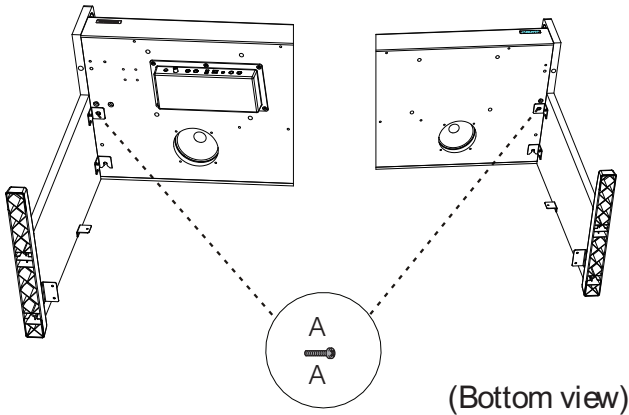

Finish attaching the piano to the stand by using the two Piano Body Bolts (A) to attach the bottom of the piano to its stand.

### **4. Connecting the Pedal Cable and Power Supply**

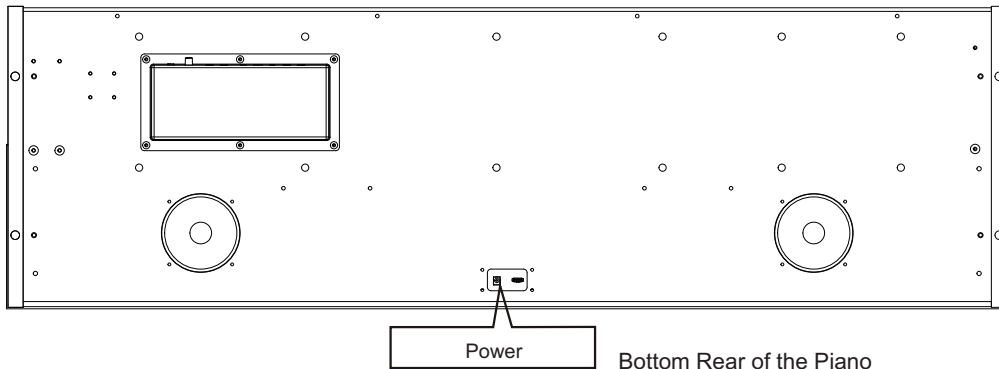

Attach the DC Adaptor and Pedal Cable into their connectors on the bottom of the piano as shown.

### **5. Installing the Headphone Holder**

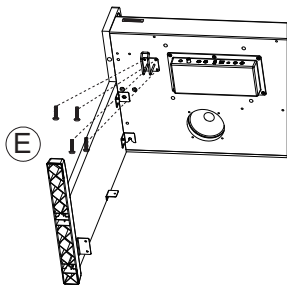

Headphone Holder Installation: Attach the headphone holder to the bottom left of the piano with the four Headphone Bolts(E).

**Bench**

A:  X4

B:    X4

C:  X4

